

FRANKLINWH

aPower 2

AC-coupled battery

Store solar generated power while the sun is shining. Use the stored energy when needed to lower electric bills. Run heavy loads such as air conditioners and water heaters as usual even during grid outages. Provide homeowner peace of mind by fully charging before severe weather events.

The system is off-grid ready, designed to operate independently from the main power grid to deliver reliable energy in any situation.

- ✓ 10 kW continuous / 15 kW peak for 10s
- ✓ 8 kW charge power
- ✓ 15 kWh AC¹ per unit, up to 225 kWh (15 units) per aGate
- ✓ 60 MWh warranty throughput



PERFORMANCE SPECIFICATIONS

SKU	APR-10K15V2-US				
Model Number	aPower X-20				
Battery Chemistry	Lithium Iron Phosphate (LFP)				
Usable System Energy	15 kWh AC ¹ per unit, up to 15 units per aGate				
Aggregate Throughput	60 MWh				
Real Power (charge)	8 kW continuous				
Nominal Output Power (AC)	2.5 kW	5 kW	6.7 kW	8.4 kW	10 kW ²
Maximum Apparent Power	2.9 kVA	5.8 kVA	7.7 kVA	9.6 kVA	11.5 kVA
Maximum Continuous Current	12 A	24 A	32 A	40 A	48 A
Nominal AC Voltage	120 / 240 V, 120 / 208 V (single phase), 60 Hz				
Coupling	AC-coupled				
Phase	2 W+N+PE				
Round Trip Efficiency	90% ¹				
Maximum Short-Circuit Current Rating	10 kA				
Load Start Capability	Up to a 5-ton air conditioner				
Work Modes	Self-Consumption Time of Use Emergency Backup				
Noise Emission	30 dB(A) Typical / 40 dB(A) Maximum				
Flood Resistance	Up to 29" from the aPower 2 base				
User Interface	FranklinWH App				
Warranty	15 years ³				

COMPLIANCE INFORMATION

Certifications	UL 9540, UL 9540A, UL 1973, UL 1741, UL1741 SB, UL 1741 PCS, UL 60730-1:2016, IEEE 1547, IEEE 1547.1, UN 38.3, CSA C22.2 No. 107.1:16
Seismic	AC 156, OSHPD, IEEE 693-2005 (high)
Environmental	California Proposition 65 RoHS Directive 2011 / EU
Emissions	FCC Part 15 Class B, ICES 003

1. At beginning of life, 3 kW charge/discharge power, 77 °F (25 °C).
 2. Refer to the installation manual and commissioning guide for proper wire and OCPD sizes.
 3. For more details, please refer to the FranklinWH System Limited Warranty for End Users available in the Documentation Center on the FranklinWH website.

MECHANICAL SPECIFICATIONS

Dimensions (H x W x D)	45.2 in x 29.5 in x 11.8 in (1149 mm x 750 mm x 300 mm)
Weight, aPower 2 Complete	357 lb. (162 kg)
Weight, without Cover	335 lb. (152 kg)
Weight, Cover	22 lb. (10 kg)
Mounting	Wall or floor mount
Cooling	Natural air-cooled design

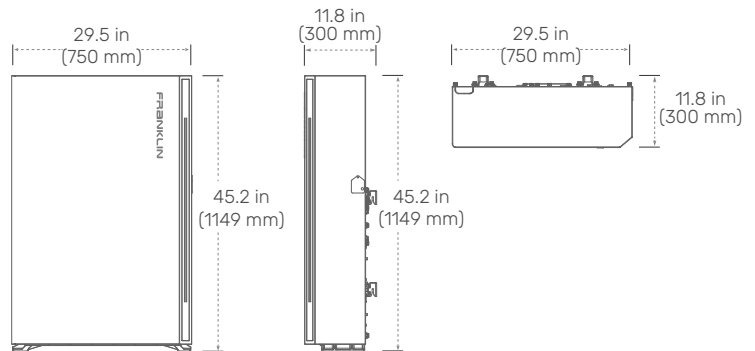

ENVIRONMENTAL SPECIFICATIONS

Enclosure Type	Type 3R
Ingress Protection	IP56 (Wiring) IP67 (Battery Pack & Inverter)
Operating Temperature	-4 °F to 122 °F (-20 °C to 50 °C) Operates up to 131 °F (55 °C) at 5kW derated output
Operating Humidity (RH)	Up to 100% RH, condensing
Altitude	Maximum 9,843 ft (3,000 m)
Environment	Indoor and outdoor rated

Compatibility Notice: At launch, the aPower 2 is compatible with the aGate 1.3 only. Compatibility with earlier aGate and aPower versions is anticipated in Q2 2025.